



INFORMATION DISPLAY TECHNOLOGY

User's Guide

Version 6

The **TruColor** **II**
Programmable Electronic Sign

WELCOME...

...to the world of electronic moving message systems! We are pleased that you have chosen the Pro-Lite *TruColorII* electronic message sign.

We trust that you will enjoy the benefits from using the Pro-Lite sign. Should you have any questions or suggestions about the Pro-Lite product, please feel free to contact us:

**E-mail: feedback@pro-lite.com | Web: www.pro-lite.com/feedback
Phone: 714-668-9988**

SO THAT WE MAY BETTER SERVE YOU...

Please write your product information down and keep handy. The information is found on the backside of the sign.

Model Number: _____

Batch/Serial Number: _____ / _____

Purchase Date: _____

REGISTRATION...

Mail your included warranty registration card today to receive additional product benefits for free!

1 YEAR MANUFACTURERS WARRANTY
FREE PHONE TECHNICAL SUPPORT
NEW PRODUCT ANNOUNCEMENTS AND PRODUCT DISCOUNTS

*Warranty card must be mailed within 30-days of purchase and accompanied by a copy of the purchase receipt to be valid. If you did not receive a registration card, please email info@pro-lite.com.

Pro-Lite, Inc. has made every effort to ensure the accuracy of this manual. However, due to continued product innovation, the information in this manual is subject to change without notice.

TRADEMARKS

Tru-ColorII and *Trivia-In-Motion* are trademarks of Pro-Lite, Inc.

TABLE OF CONTENTS

UNPACKING	1
KEYBOARD LAYOUT	2
SIGN OPERATION	
Getting Started	
Simple message, editing, deleting characters	3 - 4
Colors and Effects	
Text colors, font sizes, effects, time and date	5 - 6
Alternate Characters and Graphics	
Letters, numbers, symbols, graphics, and alternate characters	7 - 8
The TARGET Function	
Count up to target, count down to target	9 - 10
Settings and Advanced Features	
Combined pages, sign settings, custom graphics, deleting content ...	11 - 12
Instant Feature Selection	
<i>Trivia-In-Motion</i> , scroll speed, direct run page, on/off, sign reset	13
CODES TABLE	
Color Codes and Fonts Table	14
European Characters Table	15
Graphic Images Table	16
Effects and TARGET Variables Table	17
FREQUENTLY ASKED QUESTIONS	I - II
TROUBLESHOOTING	III
CUSTOMER SUPPORT	IV

UNPACKING

The complete package consists of the following items:

1. Electronic message sign
2. Wireless Infrared Remote Keyboard
3. Power adapter
4. User's manual
5. Warranty Registration Card
6. Two mounting brackets
* Wall mounting screws not included
7. 30-day TRIAL Software and Communication cable.
8. Accessories Brochure/Order Form

If you notice a missing item(s), please contact Pro-Lite, Inc. within 7 days of purchase at 714-668-9988.

INSTALLATION AND SET UP

1. Mount the brackets onto the chosen wall location. Use the mounting screws included with the display to fasten the brackets onto the sign.
2. There are two wires from the power adapter. First connect the "mains" to any 110V/120V AC wall outlet. Secondly, connect the opposite end to the sign power input.
3. The sign will automatically light up and show the "demo" message.
4. Surge protectors are recommended if you are in an area where power outages are frequent.

MOVING SIGN PANEL

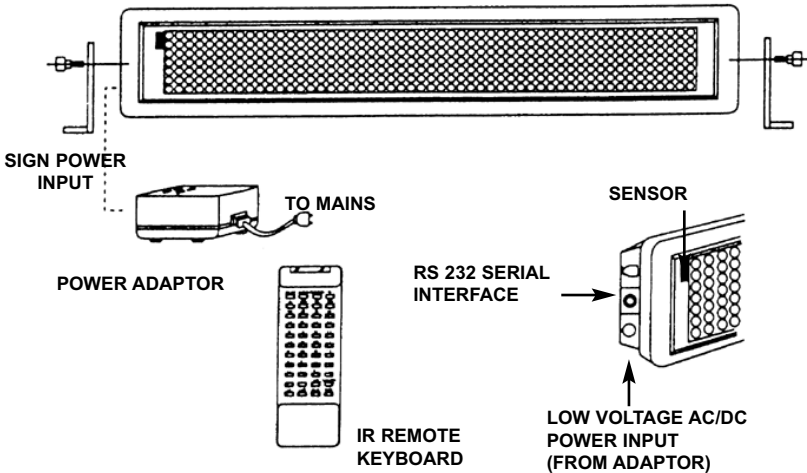

WARNING! U.S. PATENT NOTICE

Pro-Lite displays are protected by one or more U.S. Patents. Companies or individuals that copy or infringe Pro-Lite products in part or in whole will be prosecuted to the full extent possible under the law of the United States.

KEYBOARD LAYOUT

INFRA-RED REMOTE KEYBOARD LAYOUT



Command Keys

Keys located in the yellow area

Character Keys

Keys outside the yellow area

- Upper Case Keys (26) A-Z
- Lower Case Keys (26) a-z
- Numeric (10) 0-9
- Symbols (29) !; ...
- European (64) Å æ

Please refer to pages 7-8 for instructions on displaying European characters

NOTE:

- IR keyboard must be pointed at the built-in infra-red sensor located on the top left hand corner of the sign.
- Optimum operating distance should be around 5' to 30'.
- DO NOT subject the remote keyboard to impact, water or excessive humidity.
- The remote keyboard operates on two "AA" 1.5-volt batteries.
* Batteries not included

Inserting Batteries

Battery Cover

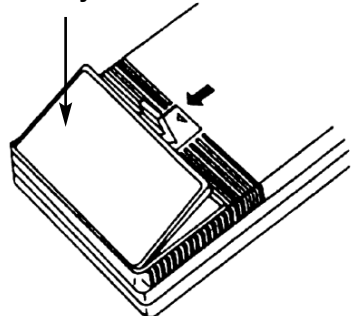



GETTING STARTED

Programming a simple message.

Let's practice how to program a simple message by following the steps below. Make sure your sign is currently running a message. We suggest turning the *Trivia-In-Motion* OFF while trying these examples. To turn the *Trivia-In-Motion* OFF, press the **FUNCTION** key while the sign is scrolling a message.

- | | Press | Display | Description |
|---|------------------------|----------------|--|
| 1. | RUN/STOP | STOP MODE | Stops the sign |
| If you find yourself on a screen you do not wish to be on, just press ESC to return to the STOP MODE screen. | | | |
| 2. | PROG | PAGE (A-Z)? A | Program a message |
| 3. | A | (PG: A START) | We have selected to program PAGE A |
| 4. | H E L L O SPACE | HELLO | Enter "HELLO" using the character keys |
| If you enter a wrong character, press DEL to delete the last character entered. | | | |
| 5. | RUN/STOP | HELLO HELLO | Runs the message you programmed |

There are 26 Pages (A - Z) available for message programming. This allows you to program multiple messages into different Pages. **For example:** If you wanted to program your message in PAGE B, you would have entered the letter B for Step 3.

Editing Your Message

Now that you have programmed a simple message, let's change that message from "HELLO" to "HELLO MY NAME IS JOE".

	<u>Press</u>	<u>Display</u>	<u>Description</u>
1.	RUN/STOP	STOP MODE	Stops the sign
2.	PROG	PAGE (A-Z)? A	Program a message
3.	A	(PG: A START)	Program PAGE A
4.	→ → → → →	HELLO	Move cursor to last letter

Use the right arrow key or the left arrow key to view and edit your programmed message.

5.	SPACE M Y SPACE N A M E SPACE I S SPACE J O E	HELLO MY NAME IS JOE	Enter "MY NAME IS JOE" using the character keys
6.	RUN/STOP	HELLO MY NAME IS JOE	Runs the message you programmed

Deleting characters using the **DEL** key.

You can easily delete characters from your message by using the **DEL** key. Let's change "HELLO MY NAME IS JOE" to "HELLO JOE".

1. Press **RUN/STOP** to stop the sign.
2. Press **PROG** to program a message.
3. Press **A** to program PAGE A. The sign will read: (PG: A START)
4. Press the **→** key until the letter "S" from the word "IS" is the last character on the right. Remember, you can use the **←** key if you scroll too far.
5. Now press the **DEL** key until the word "HELLO" is the only word seen on the sign.
6. Press **RUN/STOP** to run the message.
7. "HELLO JOE" should now be seen on the sign.



COLORS AND EFFECTS

Using the **COLOR** key to select a text color.

1. Press **RUN/STOP** to stop the sign.
2. Press **PROG** to program a message.
3. Press **F** to program PAGE F. The sign will read: (PG: F START)
4. Press the **COLOR** key. The sign will read: COLOR: A
5. Now press the right **→** or left **←** arrow keys to view the different text colors. Once you see the color you wish to use, press the **ENTER** key. Your color has now been selected. The color you select will stay active until another color is chosen or the **RUN/STOP** key is pressed to run your message.
6. Enter the word "SUCCESS" and press **SPACE** .
7. Press **RUN/STOP** to run your message.

There are 26 Text Colors to choose from. Refer to **Codes Table** for corresponding letters.

Using the **FONT** key to select font sizes.

1. Press **RUN/STOP** to stop the sign.
2. Press **PROG** to program a message.
3. Press **G** to program PAGE G. The sign will read: (PG: G START)
4. Press the **FONT** key. The sign will read: FONT: A
5. Now press the right **→** or left **←** arrow key to view the different font sizes. Once you see the font size you which to use, press the **ENTER** key. Your font size has now been selected. The font you select will stay active until another font is chosen or the **RUN/STOP** key is pressed to run your message.
6. Enter the word "SALE" and press **SPACE** .
7. Press **RUN/STOP** to run your message.

There are 8 Font Sizes to choose from. Refer to **Codes Table** for corresponding letters.

When programming a message, you can combine features without having to exit the page you are programming. **For example:** you can first select a text color, then select a font size, then enter the word you want. You can then select another text color, another font size, and enter another word.

Adding special effects to your message using the **FUNCTION** key.

Now the real fun begins! Let's program a message using the effects "CYCLING" and "RANDOM".

1. Press **RUN/STOP** to stop the sign.
2. Press **PROG** to program a message.
3. Press **H** to program PAGE H. The sign will read: (PG: H START)
4. Press the **FUNCTION** key. The sign will read: (AUTO): A
5. Press the right **→** arrow key to locate the effect "CYCLING".
6. Press **ENTER**, the sign will read: (CYCLING)
6. Enter the word "COOL".
7. Press the **FUNCTION** key. The sign will read: (AUTO): A
8. Press the right **→** arrow key to locate the effect "RANDOM".
9. Press **ENTER**, the sign will read: (RANDOM)
10. Enter the word "EFFECTS".
11. Press **RUN/STOP** to run your message.

There are 25 Effects to choose from. Refer to **Codes Table** for corresponding letters.

Displaying the **TIME** and **DATE** using the **FUNCTION** key.

1. Press **RUN/STOP** to stop the sign.
2. Press **PROG** to program a message.
3. Press **I** to program PAGE I. The sign will read: (PG: I START)
4. Press the **FUNCTION** key. The sign will read: (AUTO): A
5. Now press the right **→** or left **←** arrow keys to scroll through the various effects. Once you locate the effect "TIME", press the **ENTER** key. The sign will read: (TIME)
6. Press the **FUNCTION** key again. The sign will read: (AUTO): A
7. Now press the right **→** or left **←** arrow key to scroll through the various effects. When you locate the effect "DATE", press the **ENTER** key. The sign WILL read: (DATE)
8. Press **RUN/STOP** to run your message.

Please see page 11 for setting the current DATE and TIME.

Instant color or effect selection! **For example:** press **COLOR** and the letter **M** to use color green. This instant feature selection also works with fonts, graphics, and effects.



ALTERNATE CHARACTERS & GRAPHICS

Display lower-case Letters, numbers, and symbols using the **SHIFT** key.

1. Press **RUN/STOP** to stop the sign.
2. Press **PROG** to program a message.
3. Press **B** to program PAGE B. The sign will read: (PG: B START)
4. Press **A** to display the letter "A".
5. Press the **SHIFT** key once. Now press any one of the orange letter character keys on the IR Remote.
6. Press **SHIFT** again. Now press any one of the white number character keys on the IR Remote.
7. Press the **SHIFT** key again. Now press any one of the green symbols character keys on the IR Remote.
8. Press **SHIFT** again to return you to the upper-case mode. Press any letter key to verify that you are back in the upper-case mode.
9. Press **RUN/STOP** to run your message.

Upper-Case mode is the default selection when beginning to program. Once you press the **SHIFT** key, you are no longer in the upper-case mode. Follow steps 5 - 8 to toggle between modes.

When using the **SHIFT** key, a colored square appears to the left. Orange = lower-case; Red = numbers; Green = symbols

Display European characters using the **ALT-CHAR** key.

1. Press **RUN/STOP** to stop the sign.
2. Press **PROG** to program a message.
3. Press **C** to program PAGE C. The sign will read: (PG: C START)
4. Press **A** to display the letter "A".
5. Now press the **ALT-CHAR** key. As you will notice, the letter "A" has now changed its shape to the European letter "À". Continue to press the **ALT-CHAR** key until you reach the European style "A" of your choice.

Press any letter at any time to advance the cursor.

6. Following previous steps 4 and 5, try to display the European character for the letter "U".
7. Press **RUN/STOP** to run your message.

Display European characters in lower-case using the **SHIFT** and **ALT-CHAR** key.



1. Press **RUN/STOP** to stop the sign. Press **PROG** to program a message.
2. Press **D** to program PAGE D. The sign will read: (PG: D START)
3. Press the **SHIFT** key once to go into the lower-case mode. Remember, the **SHIFT** key toggles you from 4 different modes. Upper case, lower-case, numerical, and symbols mode.
4. Now press **C** to display the letter "C" in lower-case.
5. Now press the **ALT-CHAR** key. As you will notice, the letter "c" has now changed its shape to the European "ç".
6. Now try to display the European character for the letter "o".
7. Press **RUN/STOP** to run your message.

There are 64 European characters to choose from. Refer to **Codes Table** for corresponding letters.

Use the letter "G" with **ALT-CHAR** to display Greek characters.

Display Graphics.

Let's say we wanted to display the following message and graphic: "BIKE SALE"

<u>Press</u>	<u>Display</u>	<u>Description</u>
RUN/STOP	STOP MODE	Stops the sign
PROG	PAGE (A-Z) ?A	Program a message
E	(PG: E START)	Program PAGE E
B I K E SPACE	BIKE	Enter the word "BIKE"
GRAPHIC	Gfx (A-Z) ?: A	Select a graphic to display
P		Insert graphic "P"(bicycle)
SPACE S A L E	SALE	Enter the word "SALE"
SPACE		
RUN/STOP	BIKE  SALE	Runs your message

There are 26 pre-stored graphics to choose from. Refer to **Codes Table** for corresponding letters.



The TARGET Function

TARGET options:

1) Count Up to TARGET. 2) Count Down to TARGET.

- If you select to "Count Up to TARGET" and you set the TARGET to be reached 30 days from now, you can have your message read "2 Days have passed", "3 Days have passed", "4 Days have passed". . .

See "Count Up" to TARGET.

- If you select to "Count Down to TARGET" and you set the TARGET to be reached 30 days from now, you can have your message read "29 Days to reach our target", "28 Days to reach our target", "27 Days to . . ."

See "Count Down" to TARGET.

Interruption of power will cause the TARGET Function to reset.

"Count Up" to TARGET setup

1. Begin by setting the current DATE and TIME.
2. Press **RUN/STOP** to stop the sign.
3. Press the **TARGET** key. The sign will read: Count Up/Dn.
4. Press **U** to count UP to the specified TARGET.
5. If you want your TARGET to be reached in days, press **D**. If you want your TARGET to be reached in hours, press **H**.
6. The sign will read: TARGET: 0000. Enter the number of days or hours to specify a TARGET. **For example:** If you wanted the TARGET to be reached in 125 days, press **1 2 5**. The sign will display: TARGET: 0125

If an incorrect entry is made, enter "0" four times to clear the entry.

7. Press **ENTER**. The sign will read: START: 0000. Enter the number of days or hours to specify a start point. **For example:** If you wanted to start the counter at day 10, press **1 0**. The sign will display: START: 0010

If you selected "D" for Days in step 5, your start point in step 7 will automatically be in days. If you selected "H" for Hours, your start point will automatically be in hours.

8. Press **ENTER**. The sign will read: PAGE (A-Z)? A. Enter the PAGE LETTER you want to run when the TARGET is reached. **For example:** If you wanted to run PAGE "D" when the TARGET is reached, press **D**.
9. Press **ENTER** to confirm your entry and to start the counter.
10. The sign will read: STOP MODE
11. Press **RUN/STOP** to run the sign.

"Count Down" to TARGET setup

1. Begin by pressing **RUN/STOP** to stop the sign. Press the **TARGET** key.
2. The sign will read: Count Up/Dn. Press **D** to count DOWN to a TARGET.
3. The sign will read: DAY: 0000. Enter the number of days to start counting down from. **For example:** If you wanted to count down from 125 days, press **1 2 5**. The sign will display: DAY: 0125
4. Press **ENTER**. The sign will read: HOUR 00. Enter the current hour.
For example: If the hour is currently 10, press **1 0**.
The sign will display: HOUR: 10
5. Press **ENTER**. The sign will read: MINUTE: 00. Enter the current minutes. **For example:** If the minutes are currently 23, press **2 3**.
The sign will display: MINUTES: 23
6. Press **ENTER**. The sign will read: PAGE (A-Z)? A. Enter the PAGE LETTER you want to run when the TARGET is reached. **For example:** If your TARGET message is in Page "D", press **D**.
7. Press **ENTER** to confirm your entry and to start the counter.
8. The sign will read: STOP MODE. Press **RUN/STOP** to run your message.

Displaying a "Count Up" to TARGET variable in your message

Go to the part of your message where you want to display the variable. In this example we want to display the "Current Count" variable.

1. Press the **FUNCTION** key. The sign will read: (AUTO): A
2. Now press the **←** key until the sign reads:(COUNT): 2
3. Press **ENTER**. The sign will read: (COUNT)
4. Press **SPACE**. Press **RUN/STOP** to run your message.

Displaying a "Count Down" to TARGET variable in your message

Go to the part of your message where you want to display the variable. In this example we want to display the current "DAYS LEFT" variable.

1. Press the **FUNCTION** key. The sign will read: (AUTO): A
2. Now press the **←** key until the sign reads:(DAYS LEFT): 3
3. Press **ENTER**. The sign will read: (DAYS LEFT)
4. Press **SPACE**. Press **RUN/STOP** to run your message.

There are a 2 "Count Up" to TARGET variables and 4 "Count Down" to TARGET variables to choose from. Refer to **Codes Table** for corresponding codes.



SETTINGS & ADVANCED FEATURES

Run combined Pages using the **F1** key.

Run up to 32 pages together as one long message.

1. Press **RUN/STOP** to stop the sign.
2. Press the **F1** key. The sign will read: Page: 1)_
3. The "1)" represents the sequence number in which the Pages will run.
For example: let's say you have Pages "A", "B", and "C" programmed and you want to run them together as one long message.
4. Enter the letter **A**. The sign will read: Page: 1) A 2)_
Now enter letters **B** and **C**. The sign will read: Page: 2) B 3) C

If you make an incorrect entry, use the left **←** arrow key to move one cursor back, and then press the **DEL** key.

Inserting a new page letter will not overwrite the existing entry. The new entry will only shift the current page letter to the right.

5. Press **RUN/STOP** to run your messages together.

Setting the Password, current DATE/TIME, turning the BEEP OFF.

1. Press **RUN/STOP** to stop the sign.
2. Press **ESC** to configure the Settings of the sign.
The sign will read: Gfx Rst Set
3. Press **S** for Set. The sign will read: PASSWORD? N
4. Press **N** to NOT enter a PASSWORD. Press **ENTER** to continue.
The PASSWORD prevents others from making changes to the sign.
5. Press **Y** for YES to enter a PASSWORD.
 - a) The sign will read: PASSWORD? Y
 - b) Press **ENTER**. Enter a four letter PASSWORD. Press **ENTER**.
 - c) PASSWORD will now be requested before changes are made.
6. The sign will read: CENTURY: 19. Enter the current CENTURY.
Press **ENTER**.
7. The sign will read: YEAR: 98. Enter the current YEAR. Press **ENTER**.
8. The sign will read: MONTH: 01. Enter the current MONTH. Press **ENTER**
MONTH format: 01 =Jan, 02=Feb, 03=Mar, . . .
9. The sign will read: DAY: 01. Enter the current DAY. Press **ENTER**.
10. The sign will read: WEEKDAY: 01. Enter the current WEEKDAY.
Press **ENTER**. WEEKDAY format: 00=Sunday, 01=Monday, 02=Tuesday,
11. The sign will read: HOUR: 01. Enter the current HOUR. Press **ENTER**.
HOUR must be entered as 24 hour mode (i.e. 1p.m. =13)

12. The sign will read: MINUTE: 01. Enter the current MINUTE(s). Press **ENTER** .
13. The sign will read: 24 HOUR Y/N ?. Press **Y** to display the time as 24 hour mode (i.e. 01:00 p.m. = 13:00). Press **N** to display the time as 12 hour mode.
14. The sign will read: ID = 01. This setting is for software use. Press **ENTER** .
15. The sign will read: 9600 BAUD. This setting is for software use. Press **ENTER** .
16. The sign will read: BEEP ON. Press the right **→** arrow key to turn the "BEEP OFF". Press **ENTER** . The Settings are now set!

Custom Graphics.

To edit your own graphic you must select an existing graphic and modify it.

1. Press **RUN/STOP** to stop the sign.
2. Press **ESC** to configure the Settings of the sign.
The sign will read: Gfx Rst Set
3. Press **G** for Editing Graphics. The sign will read: Gfx(A-Z)?A
4. Press **A** to edit existing GRAPHIC "A". The sign will read:

RGYBPI  **II I**

The concept is to use the arrow keys **↑** **↓** **←** **→** to move the "dot" to the location where you want to draw. The following letters correspond to the colors you can use: **R** = RED, **G** = GREEN, **Y** = YELLOW, **B** = BLACK, as well as **P** = PLACE the "dot". **For example:** Press **B** to select the color black. Looking at the sign, press the right **→** arrow key a few times. As you will notice the red dots have now been replaced with black dots. Using this concept, try coloring an area green, yellow, or red.

5. When you are done, press **ESC** to accept changes.
6. Now when you select to display graphic A, it will show your custom design.

Delete Page(s) or Custom Graphic(s).

1. Press **RUN/STOP** to stop the sign.
2. Press **DEL**. The sign will read: Page Gfx
3. Press **P** to delete a Page(s) or press **G** to delete a Graphic(s).
4. Enter the Page or Graphic letter to delete. You can also press the **DEL** key to delete all the Pages or Graphics.
6. The screen will read: Del: A (Y/N)?. Press **Y** for YES or **N** for NO. Your selection has now been accepted.

Deleting a Graphic will restore the graphic to its original state.





INSTANT FEATURE SELECTION

Turn OFF *Trivia-In-Motion* using the **FUNCTION** key.

1. While your message is running, press the **FUNCTION** key.
2. The *Trivia-In-Motion* is now OFF.
3. To turn the *Trivia-In-Motion* ON press the **FUNCTION** key again.

SLOWING the SPEED of the sign using the   arrow keys.

1. While your message is running, press the down  arrow key to reduce the speed.
2. To increase the speed press the up  arrow key.

If power is removed from the sign, the SPEED will default to fast.

Run Page Directly!

Let's say you have Pages "A", "B", and "C" programmed. If Page "A" is currently running and you wanted to run Page "C", just press **C**. The same applies to any other Page programmed.

Turning OFF the sign without removing the power cord.

1. While your message is running, press the **ON/OFF** key.
2. Your display should now be OFF.
3. To turn ON the sign just press the **ON/OFF** key again.

RESETTING the system.

This is an excellent feature when you just want to start from the beginning.

CAUTION: This will delete all your previously stored information.

1. Press **RUN/STOP** to stop the sign.
2. Press **ESC** to configure the Advanced Settings of the sign.
The sign will read: Gfx Rst Set.
3. Press **R** for Reset. The sign will read: SURE (Y/N)?.
4. Press **Y** for YES or **N** for NO.
5. Your selection has now been accepted.

❶ CODES TABLE

Color Codes Table

To select a COLOR, press **COLOR** once, then press the Corresponding Letter.

Letter	Foreground Color	Background Color	Shadow Color	Shadow Switch
A	DIM RED	BLACK	-	OFF
B	RED	BLACK	-	OFF
C	BRIGHT RED	BLACK	-	OFF
D	ORANGE	BLACK	-	OFF
E	BRIGHT ORANGE	BLACK	-	OFF
F	LT-YELLOW	BLACK	-	OFF
G	YELLOW	BLACK	-	OFF
H	BRIGHT YELLOW	BLACK	-	OFF
I	LIME	BLACK	-	OFF
J	DIM LIME	BLACK	-	OFF
K	BRIGHT LIME	BLACK	-	OFF
L	BRIGHT GREEN	BLACK	-	OFF
M	GREEN	BLACK	-	OFF
N	LT-GREEN	BLACK	-	OFF
O	LT-YELLOW	GREEN	RED	ON
P	RAINBOW	BLACK	-	OFF
Q	RED	BLACK	GREEN	ON
R	RED	BLACK	LT YELLOW	ON
S	GREEN	BLACK	RED	ON
T	GREEN	BLACK	LT YELLOW	ON
U	GREEN	RED	-	OFF
V	RED	GREEN	-	OFF
W	ORANGE	GREEN	BLACK	ON
X	DIM LIME	RED	BLACK	ON
Y	GREEN	RED	BLACK	ON
Z	RED	GREEN	BLACK	ON

Font Size Table

To select a FONT SIZE, press **FONT** once, then press the Corresponding Letter.

Letter	Character Font Size
A	NORMAL
B	BOLD
C	ITALIC
D	BOLD ITALIC
E	FLASH NORMAL
F	FLASH BOLD
G	FLASH ITALIC
H	FLASH BOLD ITALIC

European Characters Table

To display a EUROPEAN CHARACTER, press the Corresponding Letter, then press the **ALT-CHAR** key until the European letter of your choice is reached. Once you see the European letter you wish to use, press any other letter to continue to type your message.

Letter in "UPPER CASE"	Foreground Color
A	Ă Â Á À Ä Å Æ
B	ß
C	Ç
D	Ð
E	É Ê Ë Ì
I	Í Î Ï
N	Ñ
O	Ó Ô Õ Ö Ø
P	þ
U	Ú Û Ü
Y	Ý ÿ

Letter in "LOWER CASE"	Foreground Color
a	ă â á à ä å æ
c	ç
e	é ê ë ì
i	í î ï
n	ñ
o	ó ô õ ö ø
p	þ
u	ú û ü
y	ÿ

Graphic Images Table

To select a GRAPHIC, press **GRAPHIC** once, then press the Corresponding Letter.

Letter	Graphic Pattern	Letter	Graphic Pattern
A	TELEPHONE	N	DUCK
B	GLASSES	O	MOTORCYCLE
C	FAUCET	P	BICYCLE
D	ROCKET	Q	CROWN
E	SPACE MONSTER	R	TWIN HEARTS
F	KEY	S	ARROW 1
G	SHIRT	T	ARROW 2
H	HELICOPTER	U	ARROW 3
I	CAR	V	ARROW 4
J	TANK	W	GLASS OF BEER
K	HOUSE	X	CHAIR
L	TEA POT	Y	HIGH-HEEL SHOE
M	KNIFE & FORK	Z	WINE GLASS

Graphic Patterns A-Z

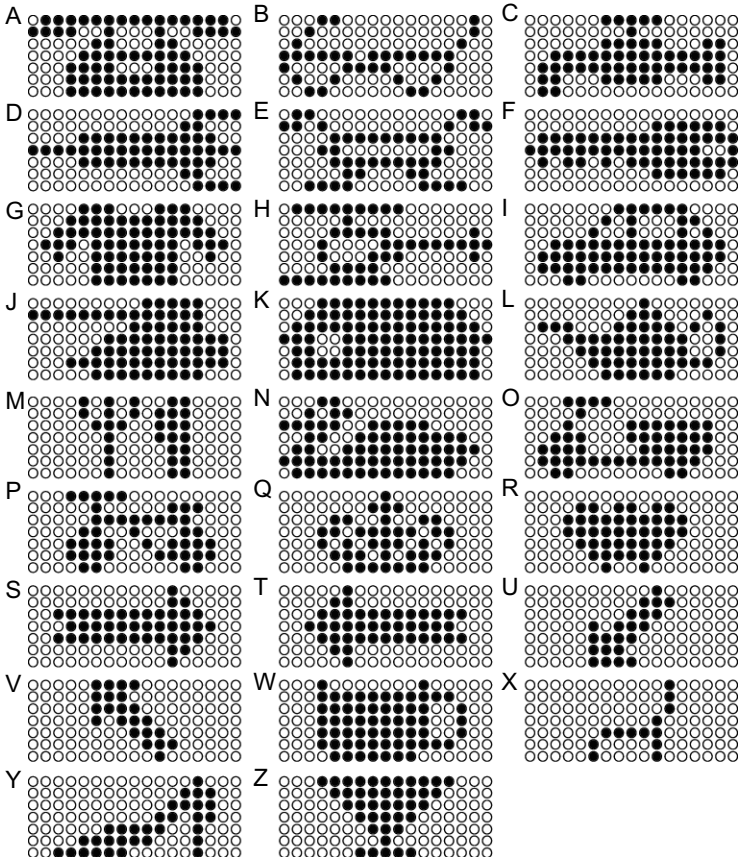

Effects Table

To use an EFFECT, press **FUNCTION** once, then press the Corresponding Letter.

Letter	Type	Effect	Description
A	L	AUTO	Shows text using all the effects randomly.
B	L	OPEN	Opens text from center to both ends.
C	L	COVER	Clears a previously displayed text from center to both ends.
D		DATE	Shows the DATE.
E	L	CYCLING	Shows text in a multi-color rolling cycle.
F	T	CLOSE ←	Clears a previously displayed text from right to left.
G	T	CLOSE →	Clears a previously displayed text from left to right.
H	T	CLOSE ►◄	Clears a previously displayed text from both ends to center.
I	L	SCROLL UP	Rotates text from bottom to top.
J	L	SCROLL DN	Rotates text from top to bottom.
K	L	OVERLAP	Shifts text in by two layers from both ends.
L	L	STACKING	Drops text from top to bottom in layers.
M	L	COMIC 1	Combines text with animated graphics #1.
N	L	COMIC 2	Combines text with animated graphics #2.
O		BEEP	BEEP sound inserted for 1 second.
P	T	PAUSE	Freezes the moving text for 1 second.
Q	L	APPEAR	Shows the text instantly.
R	L	RANDOM	Text is formed by a random formation of dots.
S	L	SHIFT	Shifts text from right to left (default).
T		TIME	Shows the TIME.
U	L	MAGIC	Shows text in a different color every time.
V		THANK YOU	Shows THANK YOU italicized using various effects.
W		WELCOME	Shows WELCOME italicized using various effects

L = Leading commands - how the text will appear - place before text.

T = Tail commands - how the text will disappear - place after text.

TARGET Variables Table

To display a COUNT UP or COUNT DOWN variable, press **FUNCTION** once, then press the <-- key to view the available count variables. When you see the one you wish to use, press **ENTER**.

Variable	Description
1 TARGET	Shows the number the count UP TARGET has been set to.
2 COUNT	Shows the current number counting UP to the TARGET.
3 DAYS LEFT	Shows the remaining days counting DOWN to the TARGET.
4 HOUR LEFT	Shows the remaining hours counting DOWN to the TARGET.
5 MINUTE LEFT	Shows the remaining minutes counting DOWN to the TARGET.
6 SECONDS LEFT	Shows the remaining seconds counting DOWN to the TARGET.

? FREQUENTLY ASKED QUESTIONS

What is *Trivia-In-Motion*?

Whether your message is simply informative or even promotional, *Trivia-In-Motion* is proven to entice people to read your programmed messages. Trivia questions and answers will automatically be inserted between your programmed messages. This will give the reader the opportunity to read your message while anticipating the answer to the question.

My audience really enjoys the *Trivia-In-Motion*, but some of them have read the same questions twice. Do you have additional *Trivia-In-Motion*?

Yes, please see the enclosed Accessories Brochure or contact Pro-Lite at 714-668-9988 for additional information.

I want to show my own *Trivia-In-Motion*, how can I do this?

Please go to our online support section for detailed instructions:
<http://www.pro-lite.com/support>.

How do I permanently remove the *Trivia-In-Motion*?

Install the included 30-day TruColor Software and use the "Remove Trivia" command. The software will also restore the *Trivia-In-Motion* onto the sign. Please keep in mind that the software is fully operational for a trial period of 30-days. After the trial period, the software will lock the user out and an unlock key will be required for continued unlimited usage. To purchase an unlock key, please call 714-668-9988.

Can I run multiple pages when the TARGET is reached?

No, you are only allowed to run 1 page.

Can I change the color of the TARGET variables?

No, these colors are fixed.

How do I remove the message pre-programmed on the sign?

The demo message is permanently programmed onto the sign and is designed to run automatically when there are no messages programmed by the user. When you program a message onto a page, the demo message will no longer show.

Will I lose my messages if I remove the power to the sign?

There is a built-in rechargeable battery in the sign. When you first purchase the sign, you must program a short message and let the sign run for a minimum of 72 hours in order for the battery to be fully charged. Once fully charged, the memory will be retained for up to 30-days without power.

How do I make letters flash?

Prior to typing your message, you will need to select the flashing font. Please refer to the instructions on page 5. Converting an existing word(s) to flash is not an available feature using the handheld remote. The TruColor software enables font changes much more easily. Try the included 30-day trial software to find out how easy it really is!

How do I display the animated graphics?

The animated graphics are part of the effects category. There are a total of 8 animated graphics. "COMIC 1" displays two animated graphics and "COMIC2" displays 6 different animated graphics. Animated graphics are random and not user selectable. Please refer to the instructions on page 6.

I programmed Pages A, B, and C. But when I press RUN/STOP only Page A will show. How do I get all of my Pages to run together?

Please refer to instructions on page 11.

I program and run my message, but it shows characters I don't want.

This is usually a programming error. Edit your message and use the arrow keys to locate the unwanted characters. When you locate them, press DEL to remove the unwanted characters. Please refer to instructions on page 4.

After I unplug my sign, I lose the current TIME and DATE setting. Why?

Clock accuracy is dependent on power, therefore when power is removed, the clock will reset to 12:00. If you would like the sign to be Off during a specific period of time, it is recommended to use the ON/OFF button instead. The time will not be effected when using this option. But power must remain connected. Please note that your messages will not be erased when power is disconnected.

Can I change the color of the TIME and DATE?

No, these colors are fixed.

How do I display lower-case letters?

Select lower-case mode. Please refer to instructions on page 7.

How do I slow the speed of the display?

In most cases, you are standing too close to the sign. The sign is designed to attract attention from an average of 15' to 100' away. Stand back at least 20 feet to view the speed of your message. If the speed is still too fast, simply use the "DOWN" arrow key to set the speed slower. To increase the speed, press the "UP" arrow key.

How much text can I program onto each PAGE?

Memory allocation is based on a combination of characters, colors, effects, and graphics used in your message. These items range from 1 byte to 126 bytes each. The *TruColorII* has 32000 bytes (32k) of total memory. A maximum of 1000 bytes can be allocated per page.

What are the advantages of using the software over the handheld remote?

- Ease of editing from the comfort of your desk
- Message simulator to see how your message will show on the sign.
- Ability to save/schedule messages for uploading at a later time
- With MiniWeb option, you are able to communicate to the sign via the LAN
- Time and Date synchronization
- Built-in graphic editor
- Upload new Trivia-In-Motion

TROUBLESHOOTING

I press **RUN/STOP** and the sign doesn't respond?

- Try using a fresh new set of batteries.
- Make sure the battery polarities are inserted in the correct direction.
- Stand 5' from the sign and point to the top left hand corner of the sign.

My sign does not show the *Trivia-In-Motion*.

- Make sure the Trivia is enabled by pressing the **FUNCTION** key while your message is running.
- You can use the enclosed 30-Day TRIAL software to upload the TRIVIA to the sign.

The sign keeps flashing, "CHECKING".

- Check the label on the power supply and see if the output is rated at 9VAC - 2.5 AMPS or higher.

I plugged the sign in but nothing comes ON?

- Unplug the power to the sign and plug it in again.
- Make sure the 9VAC plug is plugged into the sign firmly.
- Try using another outlet.

The sign does not keep memory.

- Program a short message and leave it running for at least 72 hours for the built-in battery to fully charge.
- Once fully charged, the memory will be retained for up to 30-days without power.
- Sudden power outages will interfere with sign function and cause programmed messages to be lost. As a precaution we suggest using a Power Surge Protector for added reliability.

I forgot my PASSWORD. How do I get back in to erase it?

- Stand 4' from the sign and hold down the **ESC** key while disconnecting the power from the sign.
- Now hold down the **ESC** key again while plugging the power to the sign.
- Once you have successfully bypassed the password, go back to the SETTINGS to delete or set a new password.

**You may need to repeat steps 1 and 2 several times to bypass the password.

I pressed the **F2** key and my sign blanked out?

The **F2** key is a technical support feature ONLY. If pressed accidentally while in STOP MODE, simply remove the power to the sign, wait 30 seconds and power up sign again.

Online: <http://www.pro-lite.com/support>
E-mail: support@pro-lite.com



Customer Support

All of our signs are manufactured under strict quality control for years of problem free operation. The aluminum casing minimizes interference and assures reliability wherever it is installed.

Most solutions can be found by reviewing this manual or by going online and using our step by step troubleshooting guide.

Online: <http://www.pro-lite.com/support>

If you are still unable to find a solution, please feel free to contact our Customer Support department at 714-668-9988. You can also email us directly.

E-mail: support@pro-lite.com

RETURN FOR REPAIR PROCEDURE

STEP 1

Contact Pro-Lite, Inc. to determine if your sign qualifies to be returned for repair, (714) 668-9988

STEP 2

If your sign qualifies, we will issue a Return Materials Authorization Number. This number must be written on the outside of the box that it will be returned in.

STEP 3

Ship the unit in its original container postage paid. If the original container is not available, pack the unit in a strong box made of corrugated cardboard with plenty of packing material. Unit should be returned to:

**Pro-Lite, Inc.
Technical Support Department
3505 Cadillac Ave. Bldg. D
Costa Mesa, CA 92626
RMA #**

- Units will be refused if no RMA number is found on the package.
- All units returned must be shipped postage prepaid with tracking capability.
- Units shipped COD will not be accepted.
- Pro-Lite accepts no responsibility for lost or damaged packages sent via mail or parcel company.

ONE YEAR LIMITED WARRANTY

PRO-LITE, INC. warrants to the original consumer that each of its PRO-LITE products and all components therein contained will be free from defects in materials and/or workmanship for one year from the date of purchase. Any warranty hereunder is extended only to the original consumer purchaser and is not assignable.

In the event of malfunction or other indication of failure attributable directly to faulty workmanship and/or material, PRO-LITE, INC. will at its option, repair or replace said products or components to whatever extent it shall deem necessary to restore said product to proper operating condition, provided the consumer purchaser has previously returned the enclosed Warrants Registration Card to PRO-LITE, INC. Before returning a product for repair, the customer must call PRO-LITE, INC. Customer Service at (714) 668-9988 for a Return Materials Number. This number should be included with the customer's mailing address and telephone number when the product is returned. Products should be returned to: PRO-LITE, INC., Attention: Warranty/Repair, 3505 Cadillac Ave. Bldg. D, Costa Mesa, CA 92626 (postage prepaid). During the first year after the date of purchase, all labor and materials will be provided without charge. There shall be no warranty for either parts or labor after the expiration of one year from the date of purchase. PRO-LITE, INC. does not warranty bulbs in combination or fluorescent board products.

Units must be returned postage prepaid. It is recommended that the unit be insured when shipped. Units returned for which a Warranty Registration Card has not been submitted or out-of-warranty units returned will be repaired or replaced (at the option of PRO-LITE, INC) and the customer will be charged for parts and labor

Products will be returned to customer after repair or replacement has been completed by carrier and method chosen by PRO-LITE, INC. to any destination within the United States of America. Should the customer desire some other specific form of conveyance, or be located outside the border of the U. S. then the customer must bear the cost of return shipment.

The customer shall be solely responsible for failure of any PRO-LITE, INC. product or component thereof, resulting from accident, abuse or misapplication of the product, and PRO-LITE, INC. assumes no liability as a consequence of such events under the terms of the Warranty.

This Warranty gives you specific legal rights and you also have other rights that vary from state to state.

This Warranty is in lieu of all other express warranties, which now or hereafter might otherwise arise with respect to this product. ANY AND ALL IMPLIED WARRANTIES OF MERCHANTABILITY AND FITNESS FOR PARTICULAR USE SHALL HAVE NO GREATER DURATION THAN THE PERIOD FOR THE EXPRESS WRITTEN WARRANTY APPLICABLE TO THIS PRODUCT AS SHOWN ABOVE AND SHALL TERMINATE AUTOMATICALLY AT THE EXPIRATION OF SUCH PERIOD. No action shall be brought for breach of any implied or express warranty after one year subsequent to the expiration of the period of the express written warranty. (Some states do not allow limitations or how long an implied warranty lasts, so this limitation may not apply to you.)

Incidental and consequential damages caused by malfunctions, defect, or otherwise and with respect to breach of any express or implied warranty, are not the responsibility of PRO-LITE, INC. and to the extent permitted by law are hereby excluded both for property and, to the extent of unconscionable, for personal injury damage. (Some states do not allow the exclusion or limitations of incidental or consequential damages, so the above may not apply to you.)

OTHER PRO-LITE PRODUCTS

- OUTDOOR LED DISPLAYS • INDOOR/ OUTDOOR LED CLOCKS
- MULTI-LINE LED DISPLAYS • RATE EXCHANGE LED BOARDS
- CUSTOM LED DISPLAYS • ELECTRONIC DIRECTORY BOARDS
 - FLIGHT INFORMATION SYSTEMS • QUEUEING SYSTEMS
- POINT-OF-PURCHASE LED ELECTRONICS • LED OPEN SIGNS

Please call (714) 668-9988 to receive more information on the above Pro-Lite products. Pro-Lite is a design, engineering, and manufacturer of a wide array of electronic LED products for indoor and outdoor use. View our complete product line on the World Wide Web at

www.pro-lite.com